

JE

**USO
EXTERNO**



SELLO MECÁNICO SENCILLO, PARA USO DE PRODUCTOS CORROSIVOS Y OTROS SERVICIOS

VARIOS DISEÑOS

LAS PARTES METÁLICAS NO TIENEN CONTACTO CON EL FLUIDO

FÁCIL INSTALACION

MATERIALES	
PARTES METALICAS	ACERO INOX 316 316L HASTELLOY C
	CARBON CARBURO DE TUNGSTENO CARBURO DE SILICIO STELLITE CERAMICA TFE/FIVI
CARAS	VITON BUNA AFLAS KALREZ ENCAPSULADO EPDM
ELASTOMEROS	

JE

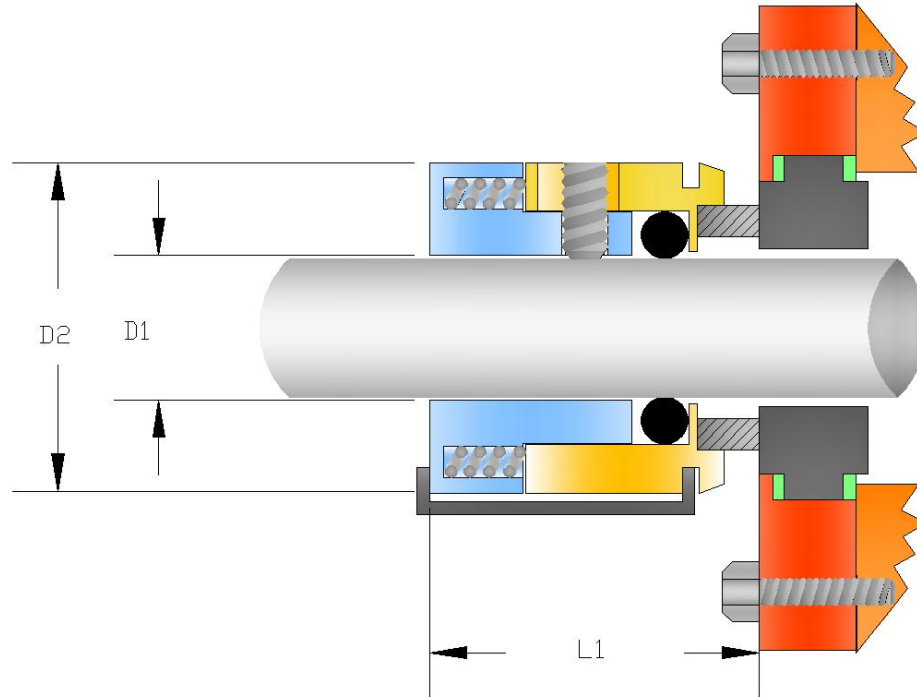

DIMENSIONES			
MEDIDA EJE	D1	D2	L1
15/16	.937	1.5935	1.437
1	1.000	1.656	1.437
1 1/8	1.125	1.781	1.437
1 1/4	1.250	1.906	1.437
1 5/16	1.312	1.9685	1.437
1 3/8	1.375	2.031	1.437
1 7/16	1.437	2.0935	1.437
1 1/2	1.500	2.156	1.437
1 5/8	1.625	2.281	1.437
1 3/4	1.750	2.406	1.437
1 7/8	1.875	2.531	1.437
2	2.000	2.656	1.437
2 1/8	2.125	2.781	1.437
2 1/4	2.250	2.906	1.437
2 3/8	2.375	3.031	1.437
2 1/2	2.500	3.156	1.437
2 5/8	2.625	3.281	1.437
2 3/4	2.750	3.406	1.437
2 7/8	2.875	3.531	1.437
3	3.000	3.656	1.437

LIMITES DE OPERACION			
PRESION	0	10 BAR	20
	0	150 PSI	200
TEMP	-20°	205° C	250°
	-40°	355° F	500°
VELOCIDAD	Vg = 15 M/S		+ - 1 mm
AXIAL	+ - 0.04		