

# SCS

## LINEA CARTUCHO



**SELLO MECÁNICO TIPO CARTUCHO, DE RESORTE UNICO CON BRIDA SENCILLA**  
**EFFECTIVO PARA INDUSTRIAS QUIMICA, TEXTIL, EMBOTELLADORAS, ALIMENTICIAS, PAPELERA, ENTRE OTRAS**  
**FÁCIL INSTALACION**

MATERIALES	
<b>PARTES METALICAS</b>	ACERO INOX 316 316L
<b>CARAS</b>	CARBON CARBURO DE TUNGSTENO CARBURO DE SILICIO STELLITE CERAMICA
<b>ELASTOMEROS</b>	VITON BUNA AFLAS ENCAPSULADO EPDM KALREZ

# SCS

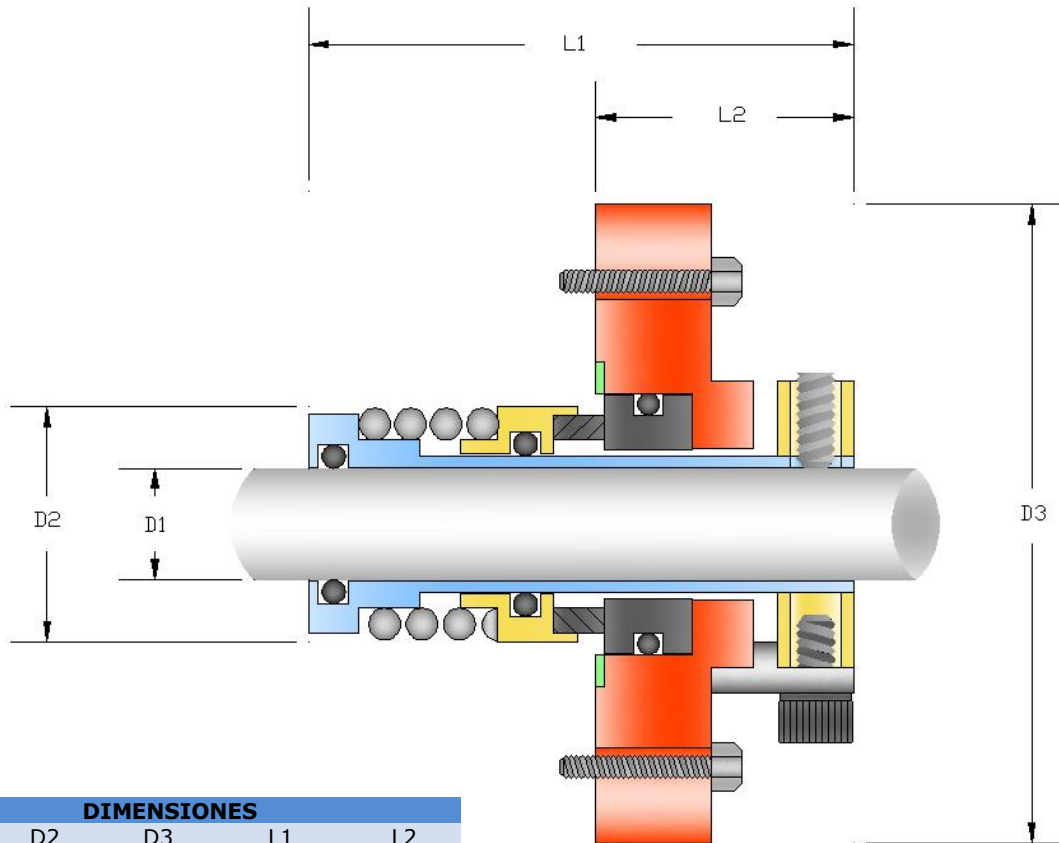
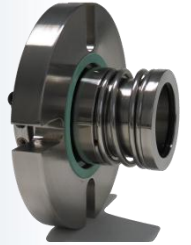

DIMENSIONES				
D1	D2	D3	L1	L2
<b>1</b>	1.562	3.875	2.724	1.281
<b>1 1/8</b>	1.687	3.875	2.853	1.281
<b>1 1/4</b>	1.812	4.000	2.865	1.281
<b>1 3/8</b>	1.875	4.000	2.865	1.281
<b>1 1/2</b>	2.062	4.500	3.085	1.343
<b>1 5/8</b>	2.250	4.500	3.361	1.343
<b>1 3/4</b>	2.375	5.000	3.400	1.343
<b>1 7/8</b>	2.500	5.000	3.439	1.343
<b>2</b>	2.625	6.000	3.580	1.405
<b>2 1/8</b>	2.750	6.000	3.580	1.405
<b>2 1/4</b>	2.875	6.375	3.619	1.405
<b>2 3/8</b>	3.000	6.375	3.659	1.405
<b>2 1/2</b>	3.125	6.375	3.722	1.467
<b>2 5/8</b>	3.375	7.250	3.722	1.467
<b>2 3/4</b>	3.500	7.250	3.722	1.467
<b>2 7/8</b>	3.625	7.250	3.840	1.467
<b>3</b>	3.750	7.250	3.958	1.467

LIMITES DE OPERACION			
PRESION	0	10 BAR	20
	0	140 PSI	200
TEMP	-20°	205° C	250°
	-40°	355° F	500°
VELOCIDAD	Vg = 15 M/S		
AXIAL			+ - 1 mm
			+ - 0.04